

## Electronics and software for Xaar™ printheads

### Robust, cost-effective solutions

- trusted and proven Xaar partner since 2008
- modular components for scalable implementation
- powerful data path and application software
- off-the-shelf, production-ready solutions



for 2001 GS12 C, 2001+ C, 2001+ U

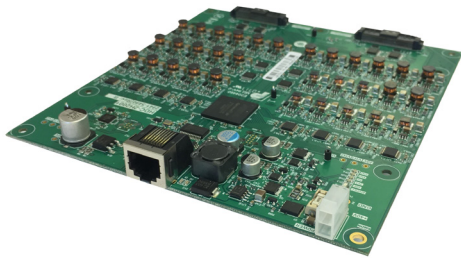

Meteor HDC-2H2001

for 1003 C, 1003 U, 1003 AMp, 1003 AMx



Meteor HDC-HLM

for 1201 (compact)

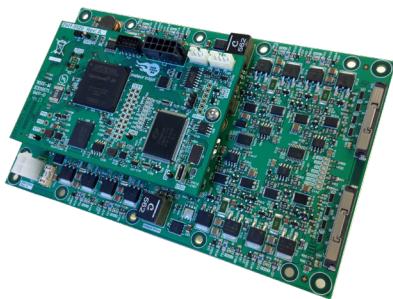

Meteor PDS-2H1201Y

for 1201 (industrial)



Meteor HDC-H1201

Meteor's comprehensive suite of software includes SDKs, application-tuned DFEs, configuration tools, embedded RIP, screening and calibration capabilities and more.

# Architecture

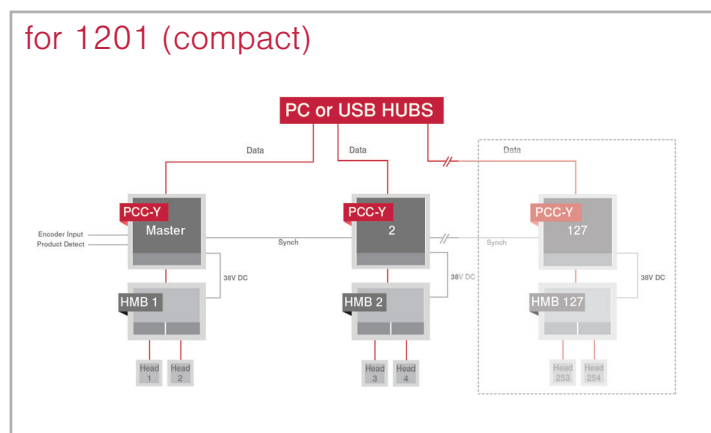
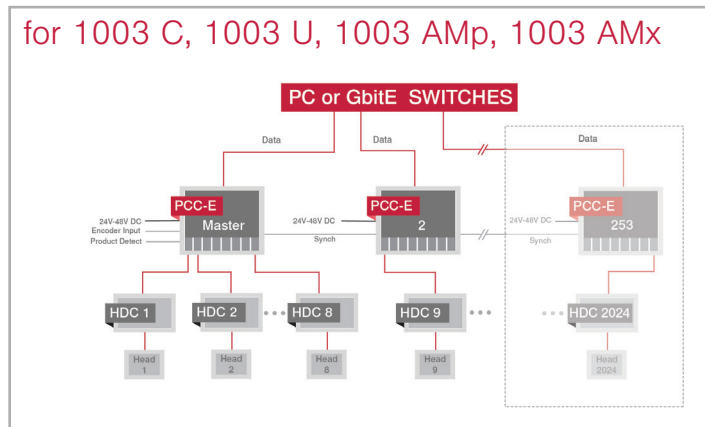
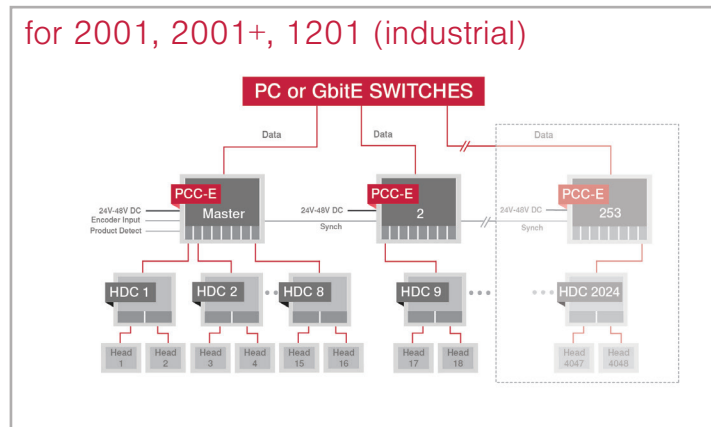

| Xaar Printhead                     | Meteor Product         | Meteor Model Number | Physical Dimensions (mm) |
|------------------------------------|------------------------|---------------------|--------------------------|
| 2001 GS12C, 2001+ C, 2001+ U       | Head Driver            | HDC-2H2001          | 140 x 150 x 22           |
|                                    | GbitE Print Controller | PCC-E               | 160 x 100 x 21           |
|                                    | Drop Tuner             | DT-H2001            |                          |
|                                    | Drop Viewer            | DV-H2001            |                          |
| 1003 C, 1003 U, 1003 AMP, 1003 AMx | Head Driver            | HDC-HLM             | 88 x 97 x 16             |
|                                    | GbitE Print Controller | PCC-E               | 160 x 100 x 21           |
|                                    | Drop Tuner             | DT-H1003            |                          |
|                                    | Drop Viewer            | DV-H1003            |                          |
| 1201 (industrial)                  | Head Driver            | HDC-H-1201          | 160 x 100 x 19           |
|                                    | GbitE Print Controller | PCC-E               | 160 x 100 x 21           |
|                                    | Drop Tuner             | DT-H1201            |                          |
| 1201 (compact)                     | Print Driver Stack     | PDS-2H1201Y         | 160 x 100 x 34           |

\*Specifications may change without prior notice.

## ALSO FROM METEOR

software • drop optimisation systems • waveform development services

Meteor Inkjet Ltd is a leading independent supplier of industrial inkjet electronics, software, tools and services. Working closely with all major industrial inkjet printhead manufacturers, Meteor offers production-ready solutions to print system builders world-wide.



Meteor Inkjet Ltd  
 Harston Mill, Royston Road,  
 Cambridge, CB22 7GG UK  
 enquiries@meteorinkjet.com  
 +44 345 8440012  
 www.meteorinkjet.com

