

## Electronics and software for RICOH™ printheads

### Robust, cost-effective solutions

- trusted and proven Ricoh partner since 2011
- modular components for scalable implementation
- powerful data path and application software
- off-the-shelf, production-ready solutions

**RICOH**  
imagine. change.

for GH2220



Meteor PDS-2GH2220Y

for MH5220, MH5420, MH522IF, MH5440,  
MH5441, MH5421, MH5421F, MH5421MF  
MH5320 & MH5340



Meteor HDC-R5

for MH2610F, MH2810F, MH2910,  
MH2420, MH2620 & MH2820



Meteor HDC-R4

Meteor's comprehensive suite of software includes SDKs, application-tuned DFEs, configuration tools, embedded RIP, screening and calibration capabilities and more.

# Architecture

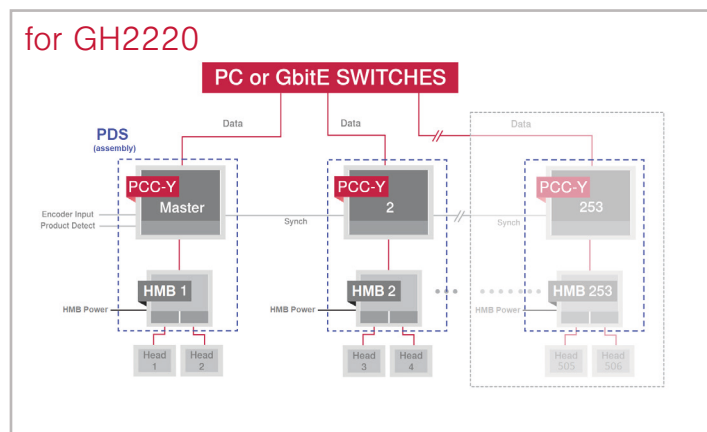
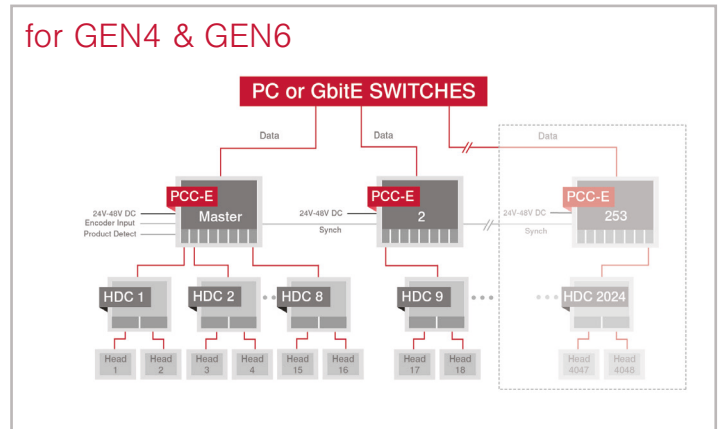
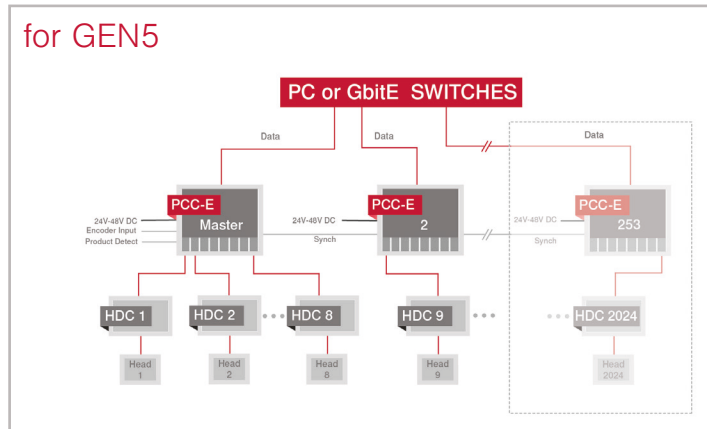

| Ricoh Printhead  | Meteor Product         | Meteor Model Number | Physical Dimensions (mm) |
|--|------------------------|---------------------|--------------------------|
| GH2220   | Print Driver           | PDC-2GH2220Y        | 100 x 100 x 14           |
|  | Drop Tuner             | DT-GH2220           |                          |
| MH5420, MH5421, MH5440, MH5220, MH5421MF, MH5221F, MH5441, MH5421F, MH5320, MH5340 | Head Driver            | HDC-R5              | 160 x 100 x 24           |
|  | GbitE Print Controller | PCC-E               | 160 X 100 X 29           |
|  | Drop Tuner             | DT-R5               |                          |
| MH2420, MH2910, MH2620, MH2820, MH2610F, MH2810F                                   | Head Driver            | HDC-R4              | 165 x 100 x 18           |
|  | GbitE Print Controller | PCC-E               | 160 x 100 x 29           |
|  | Drop Tuner             | DT-R4               |                          |

\*Specifications may change without prior notice.

## ALSO FROM METEOR

software • drop optimisation systems • waveform development services

Meteor Inkjet Ltd is a leading independent supplier of industrial inkjet electronics, software, tools and services. Working closely with all major industrial inkjet printhead manufacturers, Meteor offers production-ready solutions to print system builders world-wide.



Meteor Inkjet Ltd  
 Harston Mill, Royston Road,  
 Cambridge, CB22 7GG UK  
 enquiries@meteorinkjet.com  
 +44 345 8440012  
 www.meteorinkjet.com

