

## Electronics and software for Toshiba TEC™ printheads

### Robust, cost-effective solutions

- trusted and proven Toshiba TEC partner since 2005
- modular components for scalable implementation
- powerful data path and application software
- off-the-shelf, production-ready solutions

**TOSHIBA**  
Leading Innovation >>>

for CF3, CK3



Meteor HDC-2TT3

for CF1, CF1L, CF1XL

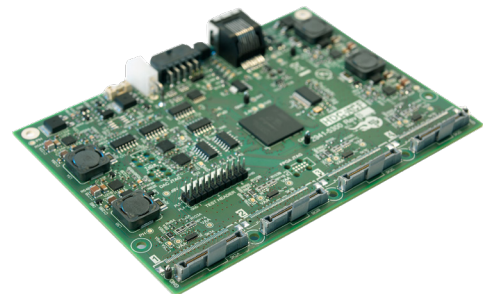

Meteor HDC-4CF1

Meteor's comprehensive suite of software includes SDKs, application-tuned DFEs, configuration tools, embedded RIP, screening and calibration capabilities and more.

# Architecture

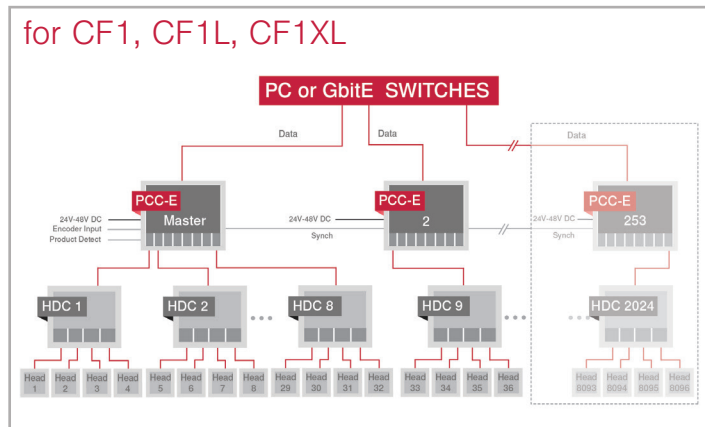
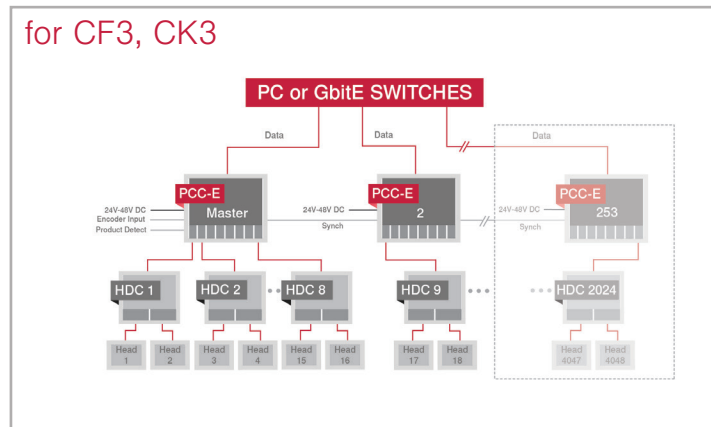

| Toshiba TEC Printhead | Meteor Product         | Meteor Model Number | Physical Dimensions (mm) |
|-----------------------|------------------------|---------------------|--------------------------|
| CF3, CK3              | Head Driver            | HDC-2TT3            | 175 x 70 x 15            |
|                       | GbitE Print Controller | PCC-E               | 160 x 100 x 21           |
|                       | Drop Viewer            | DV-TT3              |                          |
| CF1, CF1L, CF1XL      | Head Driver            | HDC-4CF1            | 140 x 100 x 19           |
|                       | GbitE Print Controller | PCC-E               | 160 x 100 x 21           |
|                       | Drop Viewer            | DV-TT1              |                          |

\*Specifications may change without prior notice.

## ALSO FROM METEOR

software • drop optimisation systems • waveform development services

Meteor Inkjet Ltd is a leading independent supplier of industrial inkjet electronics, software, tools and services. Working closely with all major industrial inkjet printhead manufacturers, Meteor offers production-ready solutions to print system builders world-wide.



Meteor Inkjet Ltd  
 Harston Mill, Royston Road,  
 Cambridge, CB22 7GG UK  
 enquiries@meteorinkjet.com  
 +44 345 8440012  
 www.meteorinkjet.com

